

EN

INSTALLATION AND OPERATION MANUAL



AIR TO WATER SPLIT TYPE
HEAT PUMP INDOOR UNIT
(HYDRONIC MODULE)

8KW
12KW
16KW

Dear user:

Thank you for using our products!

This manual is a universal version of our hydronic module for air to water heat pump unit. Although the appearance of the hydronic module you purchased may not match the appearance described in this manual, it will not affect your operation and use.

Please read carefully before use and keep this manual in a safe place for your use.

You are using our hydronic module for air to water heat pump unit, which requires regular cleaning and maintenance. If your module is not properly cleaned and maintained, its failure rate will increase and its service life will be greatly reduced.

In order to protect your legal rights, please install it by a professional.

You are using our hydronic module for hydronic air to water heat pump unit. If it is not used for a long time in winter, please ensure that the machine is powered on 24 hours a day. Make sure to drain the water from the system to avoid freezing the system.

WARNING



- The appliance shall be installed in accordance with national wiring regulations.
- This appliance is intended to be used by expert or trained users in shops, in light industry and on farms, or for commercial use by lay persons.
- This appliance is not intended for use by persons (including children) with reduced physical, sensory or mental capabilities, or lack of experience and knowledge, unless they have been given supervision or instruction concerning use of the appliance by a person responsible for their safety.
- Children should be supervised to ensure that they do not play with the appliance.
- This appliance can be used by children aged from 8 years or above and persons with reduced physical, sensory or mental capabilities or lack of experience and knowledge if they have been given supervision or instruction concerning use of the appliance in a safe way and understand the hazards involved.
- Cleaning and user maintenance shall not be made by children without supervision.
- Disconnect the power source before service or replacing parts.
- Warning: before obtaining access to terminals, all supply circuits must be disconnected.
- Disconnect the power supply before cleaning and maintenance.
- If the supply cord is damaged, it must be replaced by the manufacturer, its service agent or a similarly qualified person in order to avoid a hazard.
- An all-pole disconnection switch having a contact separation of at least 3 mm in all poles should be connected in fixed wiring.
- The appliance shall not be installed in the laundry.
- F-gas, The equipment contains fluorinated greenhouse gas R32, Global Warming Potential (GWP):677

Correct disposal of this product



This marking indicates that this product should not be disposed with other household wastes throughout the EU. To prevent possible harm to the environment or human health from uncontrolled waste disposal, recycle it responsibly to promote the sustainable reuse of material resources. To return your used device, please use the return and collection systems or contact the retailer where the product was purchased. They can take this product for environmental safe recycling.

| | Outdoor temperature | Indoor temperature |
|------------------------|---------------------|--------------------|
| Cooling mode operation | -5...46 °C | -25...40 °C |
| Heating mode operation | -28...43 °C | -25...40 °C |
| DHW mode operation | -28...43 °C | -25...40 °C |

CONTENTS

| | |
|--|-----------|
| Accessories and local purchased parts | 3 |
| 1. Safety precautions | 3 |
| 2. Structure of hydronic module | 4 |
| 3. Installation of hydronic module | 5 |
| 4. Electrical connections | 12 |
| 5. Troubleshooting | 14 |
| Names and contents of hazardous substances in the product | 15 |

AIR TO WATER SPLIT TYPE HEAT PUMP INDOOR UNIT

ACCESSORIES AND LOCAL PURCHASED PARTS

■ Accessories

| Name | Wall panel | Installation manual & energy efficiency label | Warranty card | Replacement board | Extended wire & DHW tank sensor | Y-type filter |
|----------|------------|---|---------------|-------------------|---------------------------------|---------------|
| Quantity | 1 | 1 | 1 | 1 | 1 | 1 |

| | | | |
|--|---|---|---|
| Copper tube (GB1527- 2006 Drawn tube of copper and copper alloys) | Liquid-side piping | ∅ 9.52 × 0.8 | For the connection of the refrigerant system between the outdoor unit and the hydronic module, it is recommended to use the soft copper tube (TP2M), the length of which is selected according to your actual demand. |
| | Gas-side piping | ∅ 16 × 0.8 | |
| Rigid polyethylene plastic pipe | Outer diameter [mm] | Remarks | |
| | 25 | The drain pipe is used to connect the hydronic module. Its length is selected according to your actual demand | |
| Insulation case | The thickness of the insulation case for refrigerant-side pipeline is usually more than 15 mm, and that of insulation case for the water-side pipeline more than 20 mm. For the pipeline in the enclosed wet area, the case shall be properly thickened | | |
| Automatic water supply valve | Purchase according to your actual demand, (maximum water temperature: 80 °C, set pressure: 1.5 bar) | | |
| Water distributor & collector | When installing floor heating, purchase according to actual demand (requiring the automatic flow adjustment) | | |
| Floor heating pipe | When installing floor heating, purchase according to actual demand (∅ 20, PE-RT tube) | | |
| Room thermostat | When installing floor heating, purchase according to actual demand (requiring linkage control) | | |
| Buffer tank | When installing floor heating, purchase according to actual demand (the tank does not provide domestic hot water, the recommended tank volume: 100...200 l) | | |

1. SAFETY PRECAUTIONS

WARNING



- The installation position of the hydronic module must be protected against rain.
- Please entrust a dealer or professional to install. The installer must have relevant professional knowledge. Do not install by yourself, the improper installation will cause fire, electric shock, injury, water leakage and other accidents.
- If you need to purchase in local place, please purchase our designated products.
- If you purchase the products which are not designated by our company, it may result in fire, electric shock, water leakage, etc. The retail products shall be installed by a professional.
- Observe the regulations of the local electrical regulations when making power connections.
- According to the law, reliable grounding work must be carried out. If the grounding is not perfect, it may cause electric shock.
- When the heat pump or water heater needs to be moved or reinstalled, please let the supplier or professional to operate.
- Improper repairing may result in fire, electric shock, injury, water leakage, etc. It must be repaired by the supplier or professional.

ATTENTION



- Make sure the drain pipe can drain smoothly. Improper pipe installation may result in water leakage, wet furniture, etc.
- Check if the leakage protection switch is installed. The earth leakage protection switch must be installed, otherwise it may cause electric shock.
- It is prohibited to install the unit in a place where flammable gas is easily leaked. If the flammable gas leaks and traps around the indoor unit, it may cause fire accident.
- Confirm the installation foundation and hoisting is firm and reliable. If the foundation and hoisting are not strong enough, it may cause accident of falling objects.
- Connect the cable correctly. If the cable is connected incorrectly, it may damage the electrical components.
- Exposing the unit to water or moisture prior to installation may cause short circuits in electrical components. Do not store it in a wet basement or expose it to rain or water.
- If the refrigerant leaks during installation, immediately ventilate the room. If the refrigerant leaks out and comes into contact with the fire, it may produce toxic gases.
- After the installation work is completed, confirm that the refrigerant is not leaking.
- If the refrigerant leaks into the room and comes into contact with a fire source, such as a heater, stove or rice cooker, toxic gases may be generated.

2. STRUCTURE OF HYDRONIC MODULE

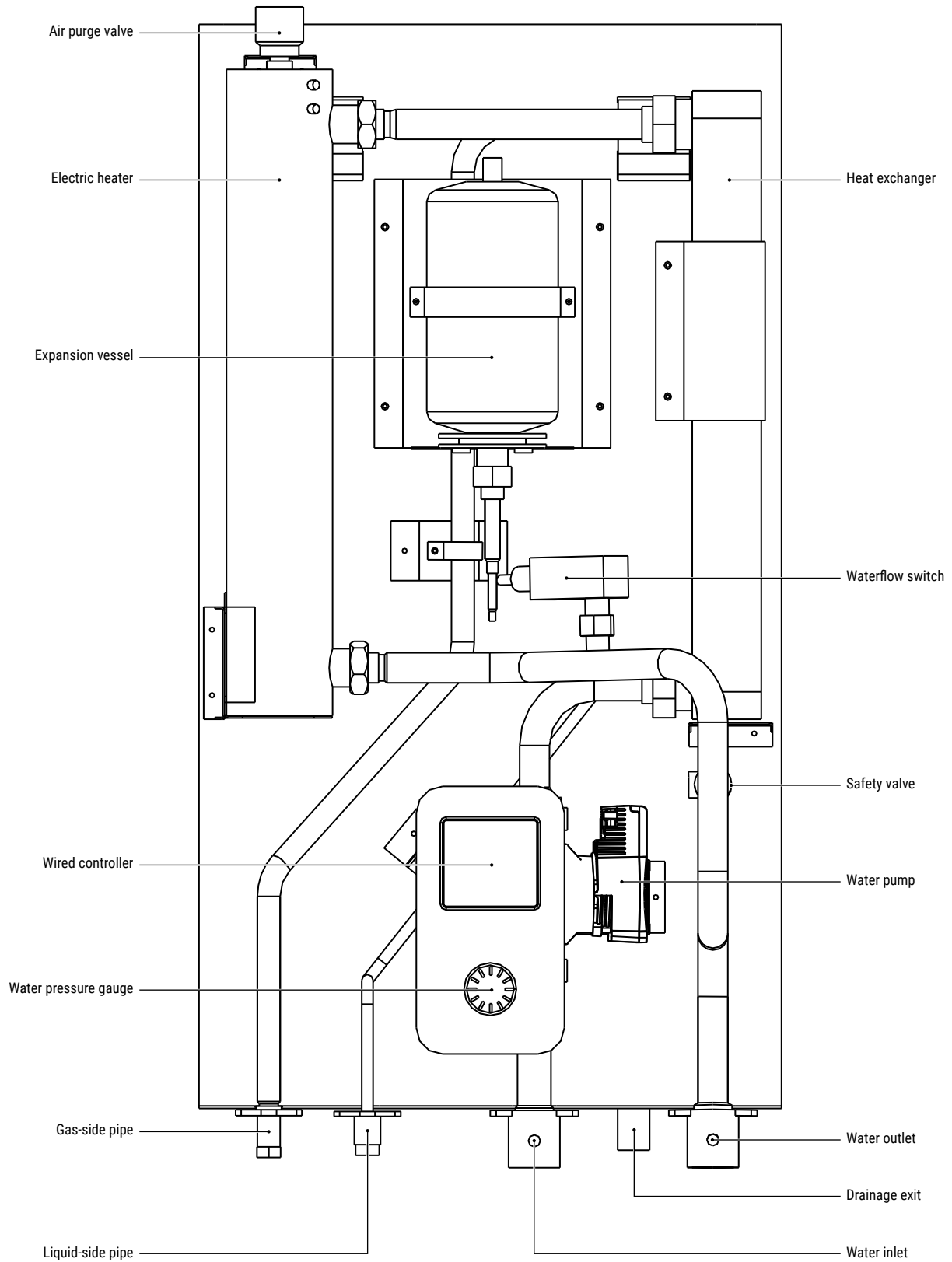

This figure is only for explaining the name of each component. Please refer to the actual product for details.

AIR TO WATER SPLIT TYPE HEAT PUMP INDOOR UNIT

3. INSTALLATION OF HYDRONIC MODULE

3.1 Space required for installation and maintenance

The size of the wall panel mounted on the wall, in mm. (See Figure 3.1)

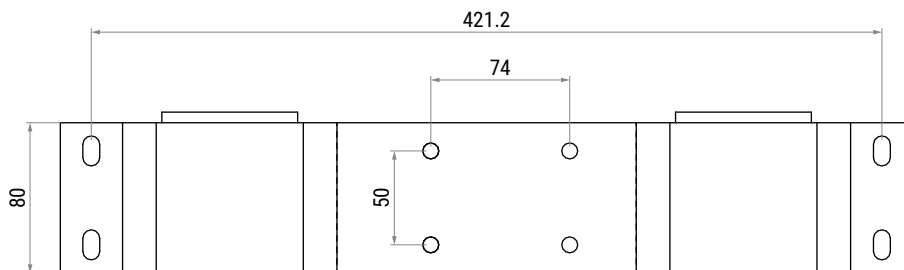

Figure 3.1

Space required for installation and maintenance, in mm. (See Figure 3.2 and 3.3)

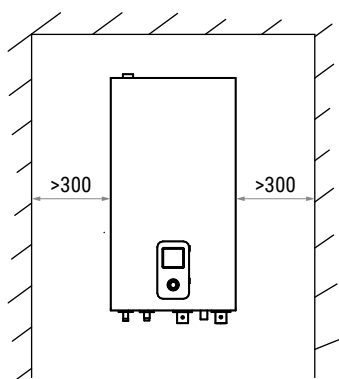

Figure 3.2

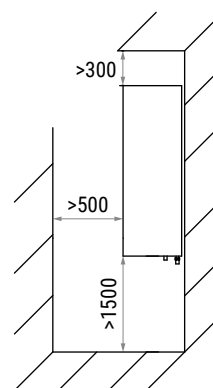

Figure 3.3

3.2 Outline dimensions and installation dimensions

(Unit: mm, see Figure 3.4)

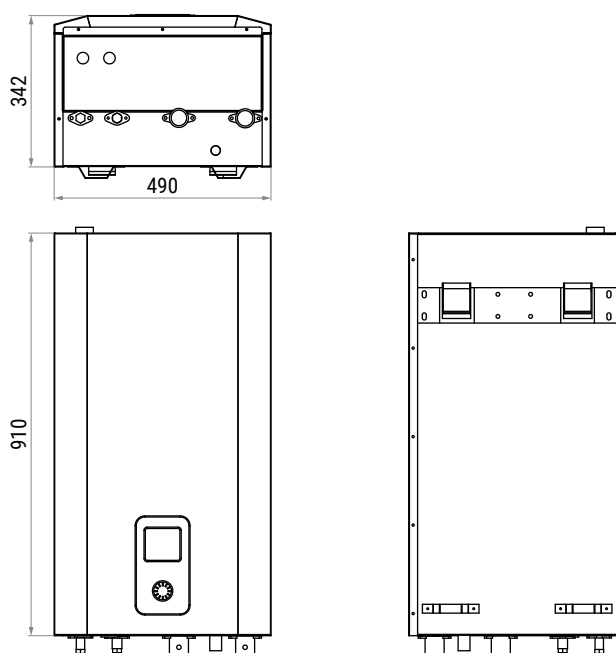

Figure 3.4

3.3 Handling

- To avoid damage during shipping, please do not open the carton until installation.
- The hydronic module is heavy and requires at least two people to handle.
- When handling the unit, please take the protective measures.
- When handling the unit, please take protective measures for the surface of the unit to prevent damage to the unit panel.

3.4 Installation diagram of hydronic module

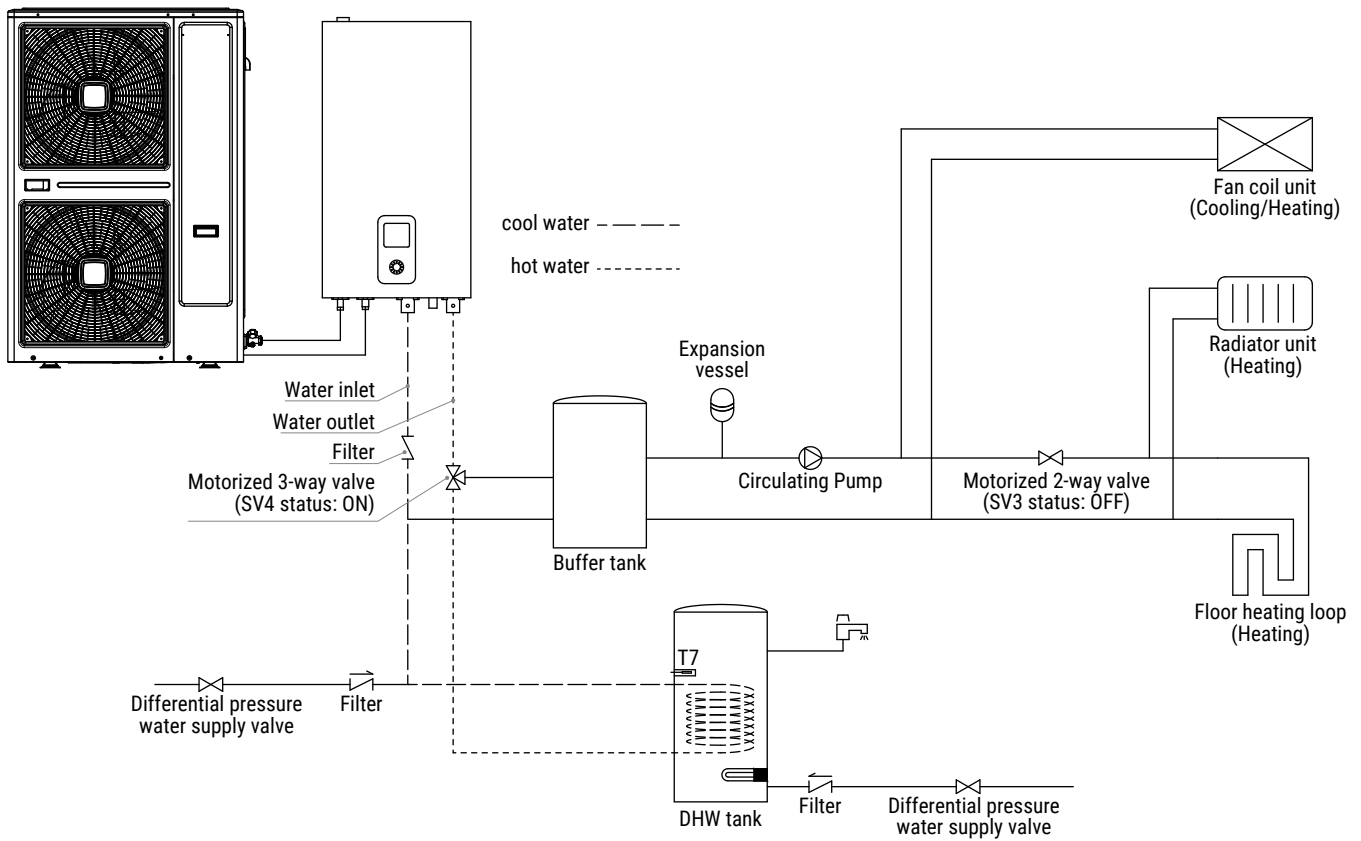

Figure 3.5 DHW Mode operation

AIR TO WATER SPLIT TYPE HEAT PUMP INDOOR UNIT

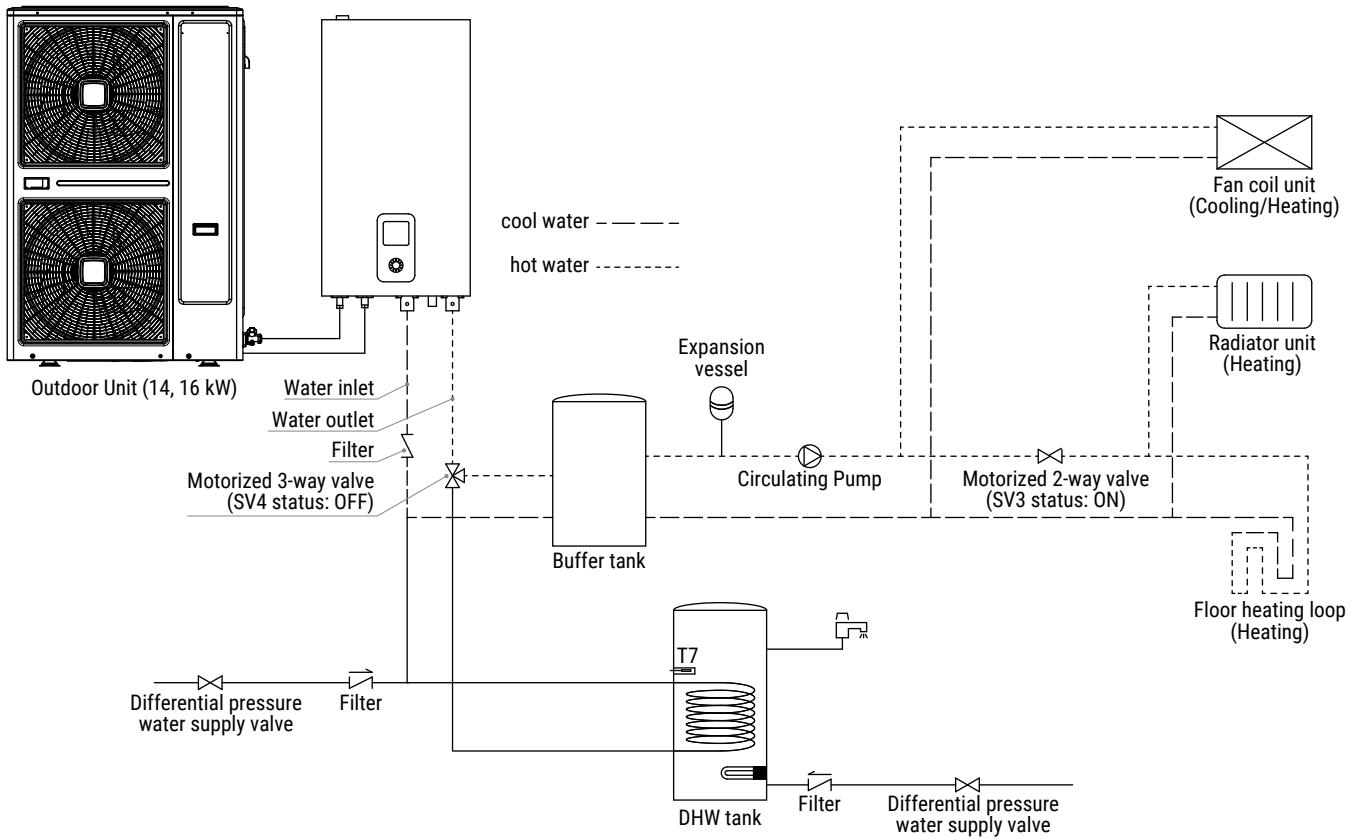

Figure 3.6 Heating Mode operation

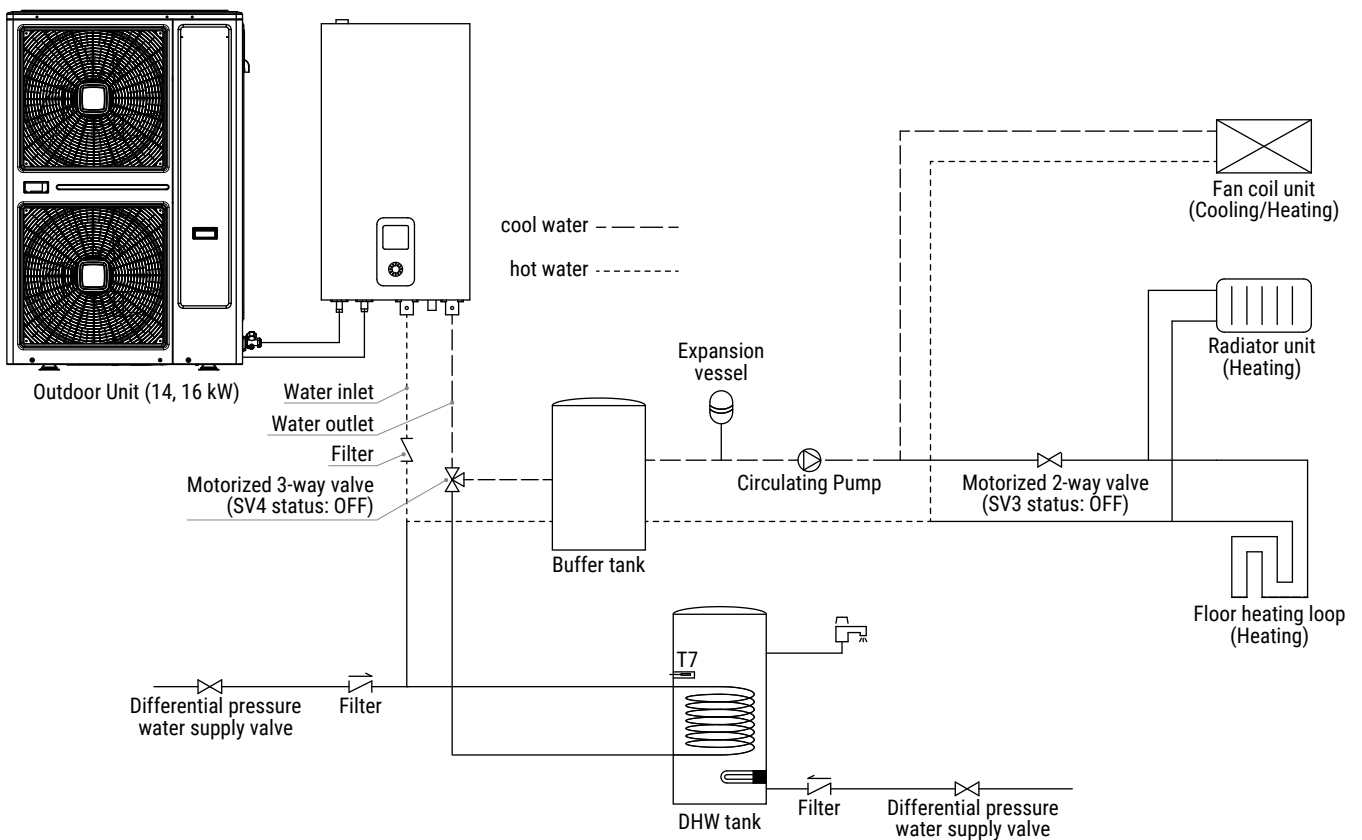

Figure 3.7 Cooling Mode operation

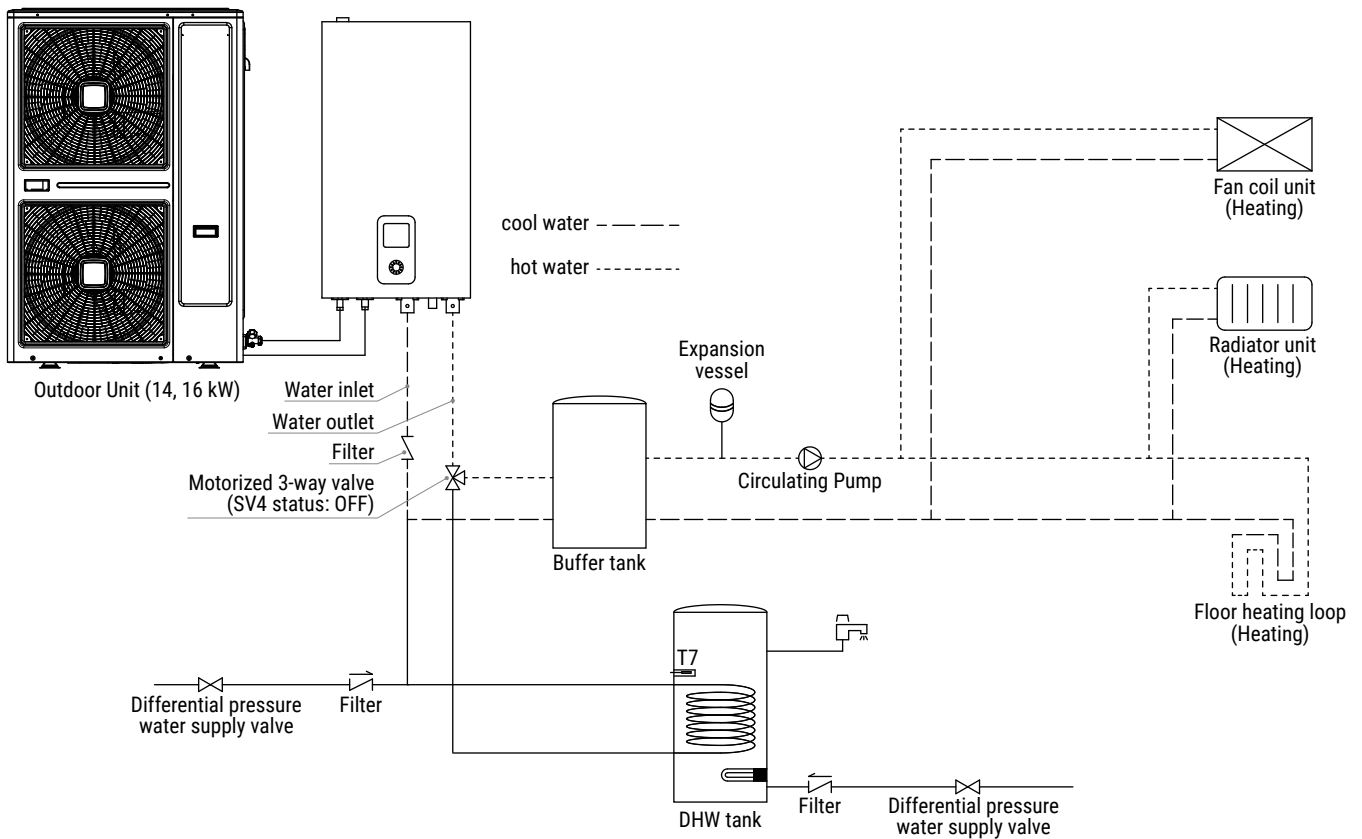

Figure 3.8 Heating Mode operation (Without Cooling Mode) operation

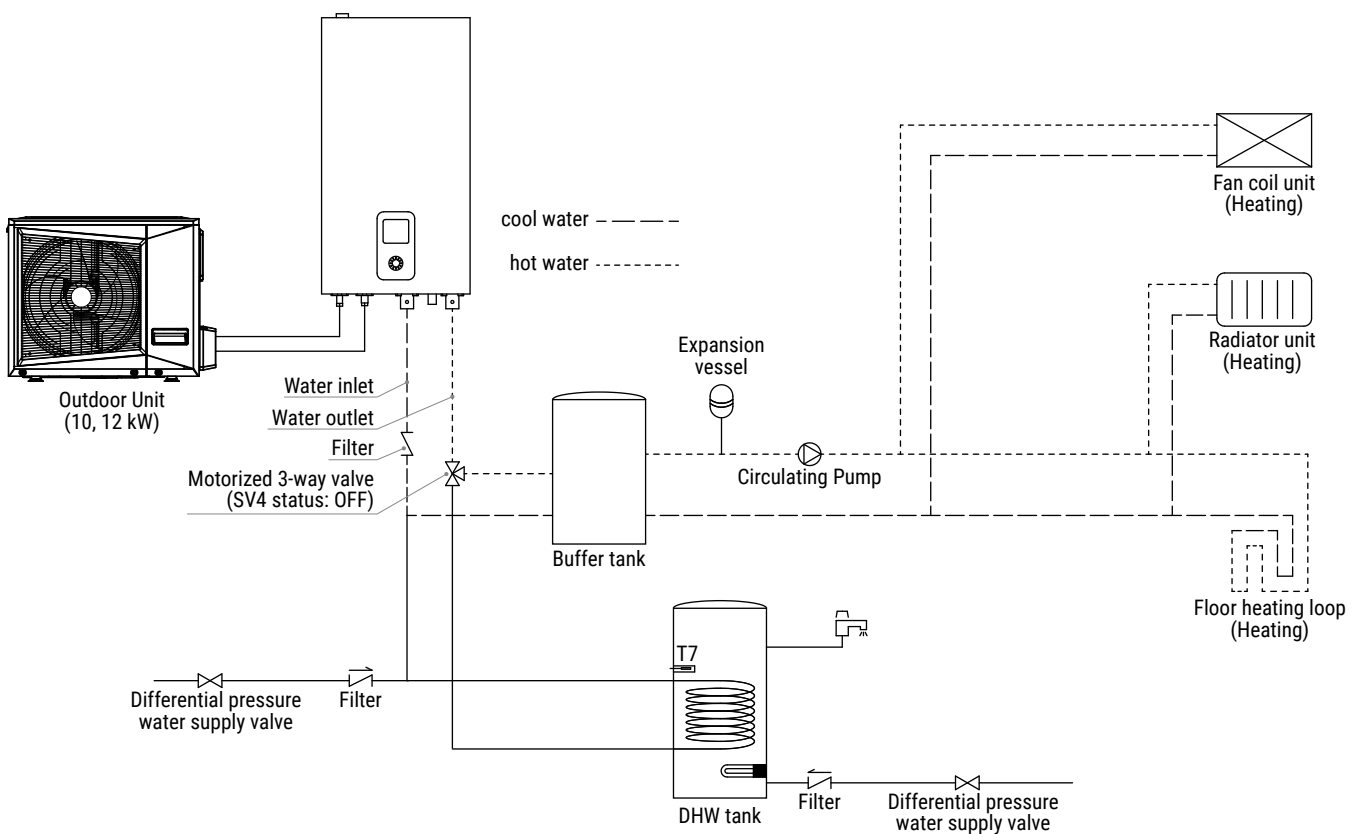

Figure 3.9 Heating Mode operation (Without Cooling Mode)

AIR TO WATER SPLIT TYPE HEAT PUMP INDOOR UNIT

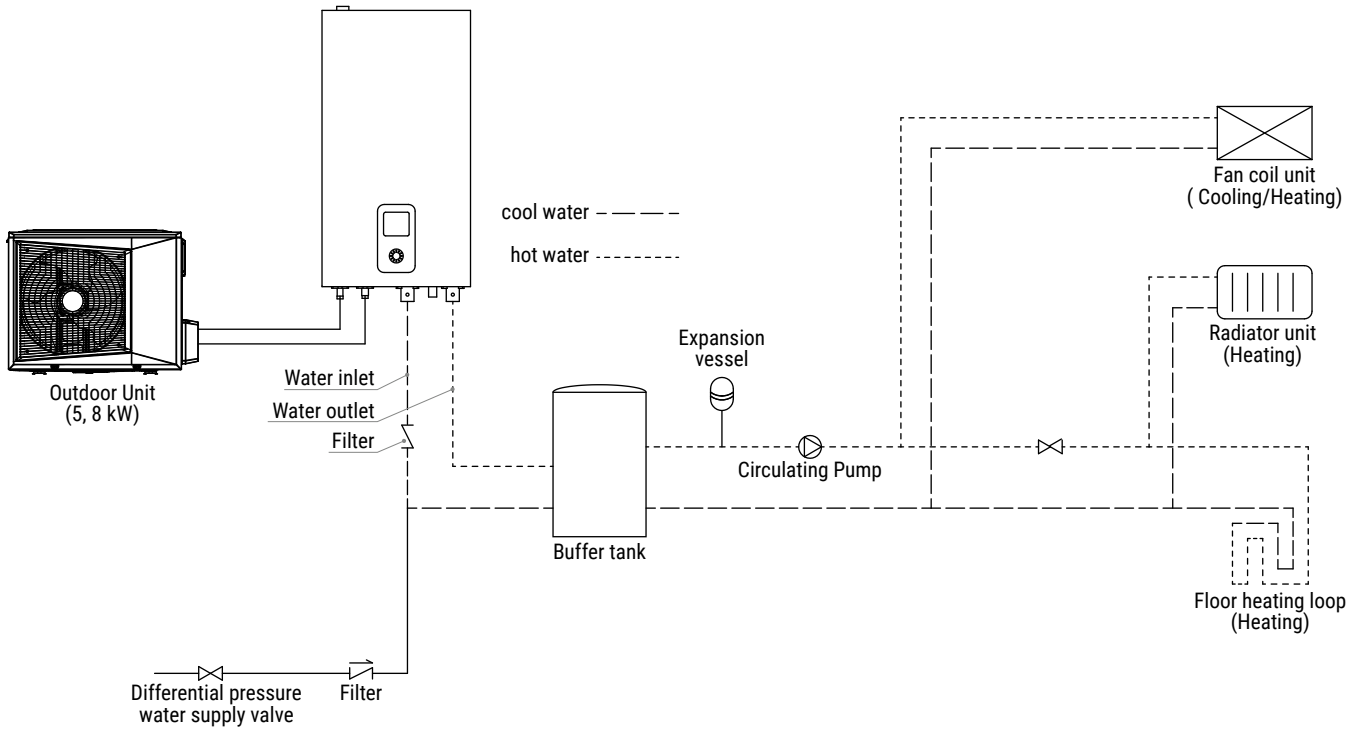

Figure 3.10 Heating Mode operation (Without DHW Mode & DHW Tank)

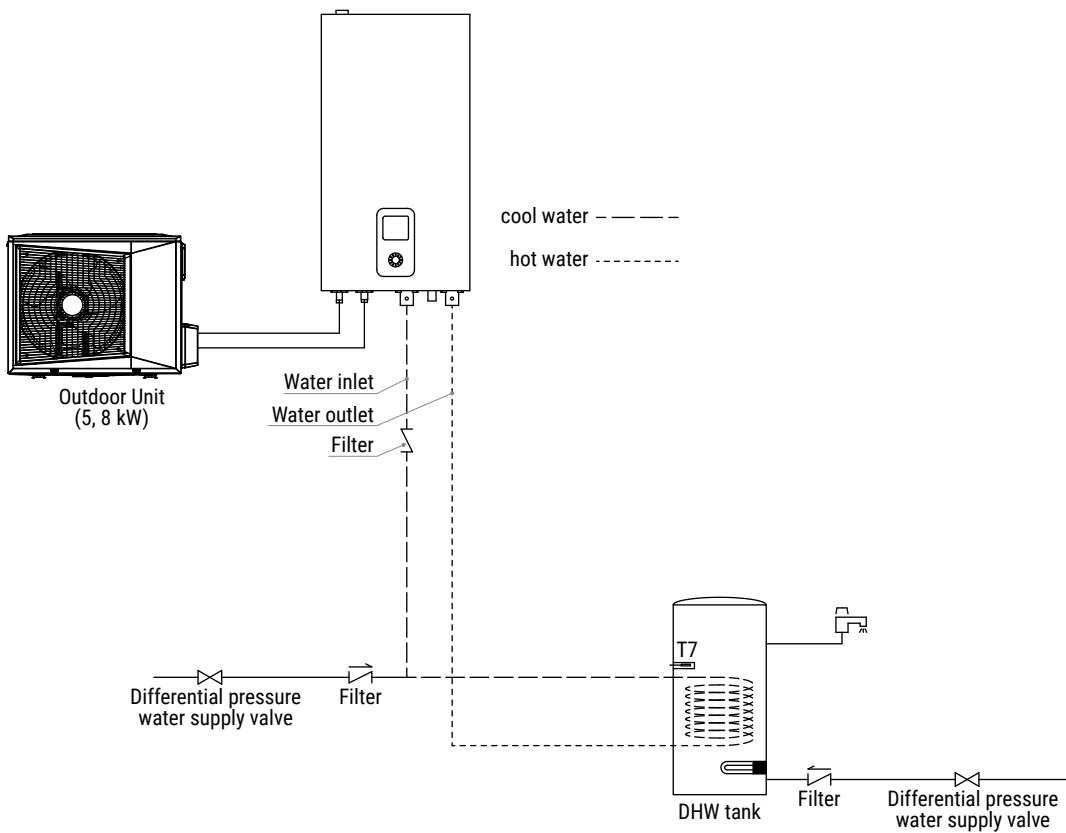

Figure 3.11 DHW Mode operation (DHW Mode only)

■ 3.5 Installation and connection of hydraulic module and terminal

The hydronic module and the terminal water system are recommended to be connected in the same way (the following is a case of a fan coil, the floor heating and radiator are similar)

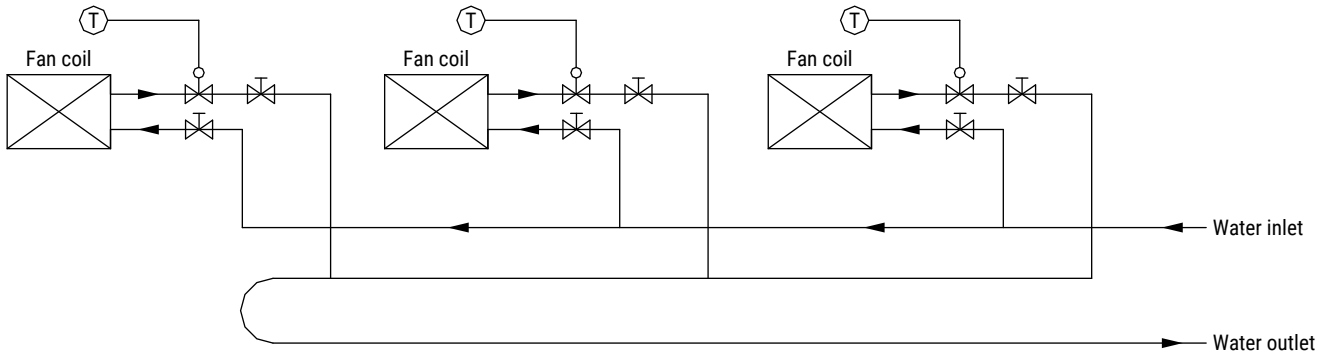

Figure 3.12

WARNING



- The temperature of supplied water in the tank shall not exceed 50 °C.
- The water quality shall meet the values specified in the following table. Otherwise, the scaling will appear in the heat exchanger and the floor heating system after a period of use, which will affect the heat exchange efficiency and cause failure.

| | | | | | |
|--------------------|-----------------------|---------------------|--------------------|--------------------|--------------------|
| Ph value | Total hardness | Conductivity | Sulfide ion | Chloride | Ammonia ion |
| 6.5 – 8.0 | 200 µV / cm | < 50 ppm | N/A | < 50 ppm | N/A |
| Sulfate ion | Silicon | Iron content | Sodium ion | Calcium ion | |
| < 50 ppm | < 30 ppm | < 0.3 ppm | No request | < 50 ppm | |

WARNING



- The refrigerant circuit of the hydronic module contains a small amount of Nitrogen, which is used to keep the pressure and detect leakage. When installing, unscrew the nut of the refrigerant pipe joint of the hydronic module. If there is no gas flowing out, check the refrigerant circuit of the unit for leakage. Install and operate only after confirming no leakage.
- When the ambient temperature is below 0 °C, be sure to keep the unit energized when the unit is not running.
- If the unit cannot be energized, drain the water from the hydronic module, the water tank and each water line, so as to avoid freezing the equipment and piping.

■ 3.6 Installing the hydronic module

As the hydronic module is heavy, it needs at least two people for installation.

1. Choose a wall or support that is fully reliable and safe to withstand twice the weight of the unit.
2. Fix the mounting bracket of the unit on the wall with 8 expansion bolts. (the minium mounting hole diameter is 8.5 mm)
3. In order to ensure the reliability of the load-bearing, the wall drilling hole needs to reach a depth of 45~50 mm. Make sure that the brackets on the wall are installed horizontally. Otherwise, the air in the water circulation system will not be easily discharged and cause the unit malfunction.
4. Hang the hydronic module on the mounting bracket on the wall.

■ 3.7 Water pipe connection



ATTENTION

- When connecting the water pipeline, be sure to tighten them with two wrenches.
- Please check if the exhaust valve in the hydronic system can normally release the air in the water circulation system.

| | Water pipe specification |
|--------------------|---------------------------------|
| Outlet pipe | DN32 |
| Inlet pipe | DN32 |

AIR TO WATER SPLIT TYPE HEAT PUMP INDOOR UNIT

■ 3.8 Water injection and antifreeze measures

Water injection and air exhaust

1. The exhaust valve should be installed at the highest point of the water system piping, and the drain valve should be set at the lowest point.
2. After the outdoor unit and hydronic module are installed, turn off the power.
3. Open the water inlet valve, unscrew the exhaust valve on the hydronic module, and fill the water system of the hydronic module. The air in the system can be gradually discharged through the exhaust valve and the water outlet of the water tank.
4. Check the water circulation system for leakage.
5. If there is no leakage in the system pipeline, power on and start the machine. After the pump runs, exhaust the air in the system through the exhaust valve and the water outlet of the water tank. After the sound of the air exhausting cannot be heard, close the exhaust valve on the hydronic module and the water outlet valve of the tank.
6. For the system without installing the water tank, exhaust air through the air exhaust valve on the hydronic module and waterway system.

Antifreeze measures

1. When the ambient temperature is below 0 °C, be sure to keep the unit energized.
2. If the unit cannot be energized, drain the water in the hydronic module, buffer tank and water wires to avoid freezing the equipment and pipeline.
3. Follow the steps below to drain the water from the tank.
 - a. Turn off the power;
 - b. Close the water inlet of the water tank;
 - c. Open the water tank outlet and drain valve;
4. Follow the steps below to drain the water from the hydronic module.
 - a. Turn off the power;
 - b. Close the water supply valve;
 - c. Open the drain valves on the circulating water inlet and the outlet of the hydronic module.

4. ELECTRICAL CONNECTIONS

4.1 Electrical wiring



ATTENTION

- The hydronic module should use a dedicated power supply. The supply voltage should conform to the rated voltage.
- The external power supply circuit of the hydronic module must be grounded, and the ground wire of hydronic module should be reliably connected to the external ground.
- Wiring construction must be carried out by a professional technician in accordance with the circuit diagram.
- The connected fixed line must be equipped with an all-pole disconnection device with at least 3 mm contact separation. The power wire and signal wire should be arranged neatly and reasonably, and should not interfere with each other, and should not be in contact with the connecting pipe and the valve body. It is not allowed to connect the two wires unless the joint is firmly welded and covered with insulating tape.
- After the wiring is completed, the power can be turned on after careful inspection

Detailed parameters of power supply

| | |
|--|------------------------------|
| Model | 8KW, 12KW, 16KW |
| Voltage [V / 50 Hz] | 220-240 |
| Power wire [mm ²] | 3-core 3×4.0 |
| Fuse [A] | 32 |
| Weak electrical signal wire [mm ²] | 3-core shielded cable 3×0.75 |

4.2 Dial selection instructions

Dial code for a different models

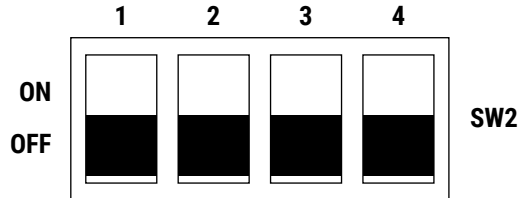

SW 2_1: OFF Heating and cooling unit
 SW 2_1: ON Heating only unit

Room thermostat

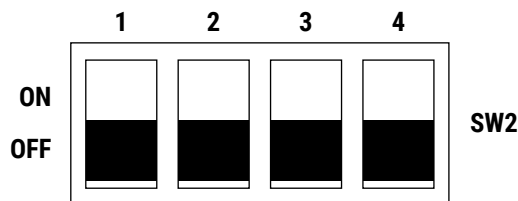

SW 2_2 :OFF Without room thermostat control
 SW 2_2 :ON With room thermostat control

DHW Mode

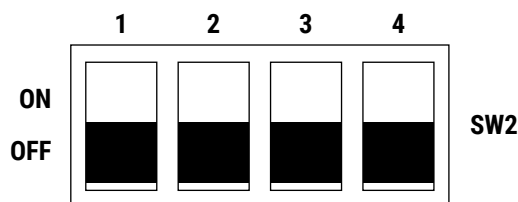

SW 2_4 :OFF With DHW Mode
 SW 2_4 :ON Without domestic hot water function

AIR TO WATER SPLIT TYPE HEAT PUMP INDOOR UNIT

4.3 Circuit diagram

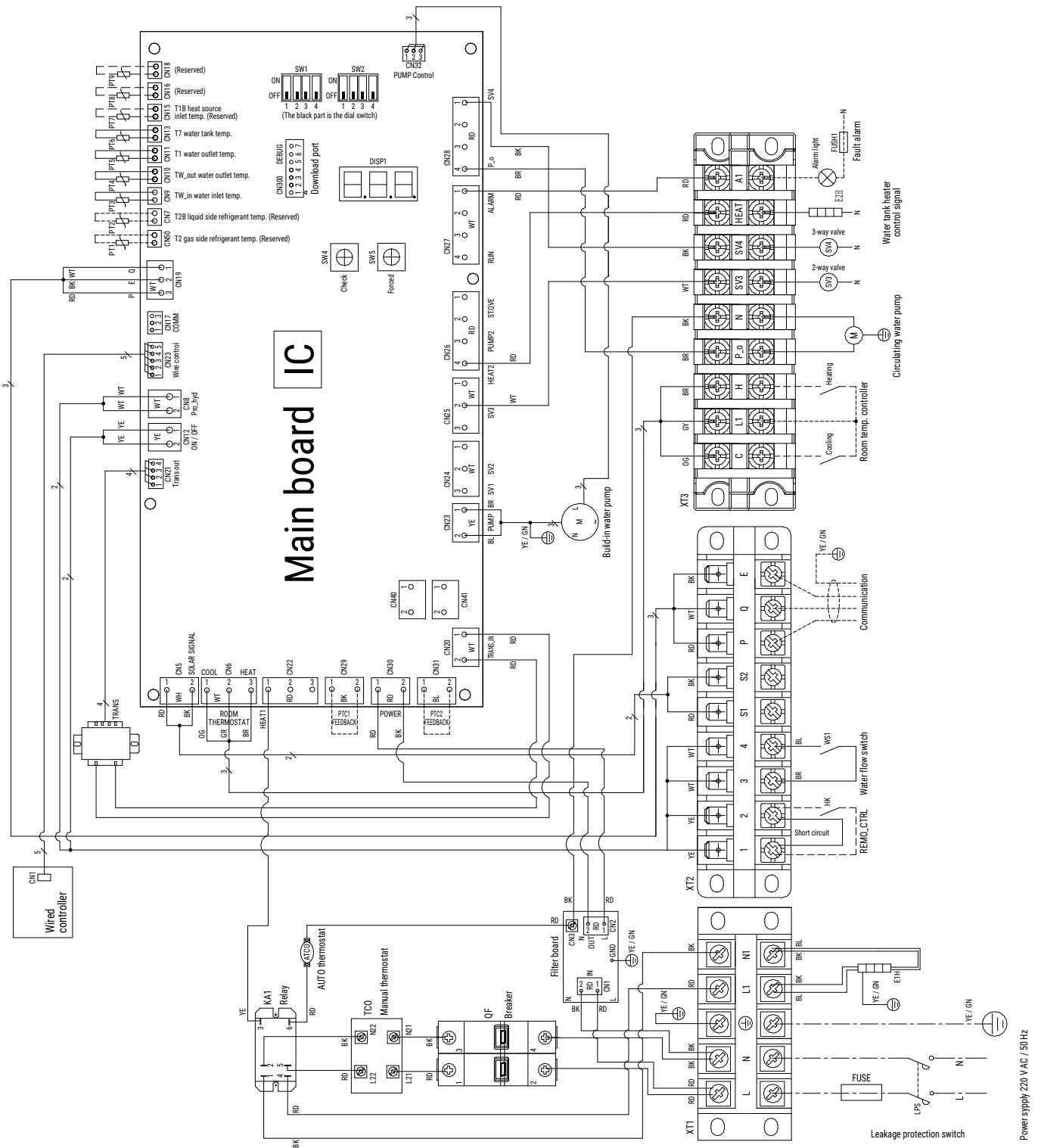

5. TROUBLESHOOTING

■ 5.1 Fault codes

| | |
|----|--|
| E0 | Water flow switch fault |
| E1 | Communication fault between the hydronic module and outdoor |
| E2 | T1 fault of outlet water temperature sensor |
| E5 | Outdoor unit fault |
| E6 | T7 fault of DHW tank water temperature sensor |
| E7 | Tw_in fault of heat exchanger inlet water temperature sensor |
| E8 | Tw_out fault of heat exchanger outlet water temperature |
| E9 | Communication fault between the hydronic module and wired controller |
| P0 | EEPROM protection |
| P1 | Protection for large temperature difference of inlet and outlet |
| P2 | Protection against insufficient water flow |
| P3 | T1 and Tw_out simultaneous fault protection |

■ 5.2 Spot inspection information sheet

| | |
|----|--|
| 1 | Horsepower of an outdoor unit |
| 2 | Set mode of an indoor unit |
| 3 | Operating mode of an outdoor unit |
| 4 | Operating capacity demand for an indoor unit |
| 5 | Set temperature |
| 6 | T1 temperature |
| 7 | Tw_in temperature |
| 8 | Tw_out temperature |
| 9 | T7 temperature (DHW Tank Temperature) |
| 10 | T4 ambient temperature |
| 11 | Previous fault |
| 12 | Previous second fault |
| 13 | Previous third fault |
| 14 | Software version |
| 15 | Pump output level |

AIR TO WATER SPLIT TYPE HEAT PUMP INDOOR UNIT

NAMES AND CONTENTS OF HAZARDOUS SUBSTANCES IN THE PRODUCT

| Part name | Hazardous substance | | | | | |
|---------------------------------------|---------------------|--------------|--------------|-------------------------------|-------------------------------|--------------------------------------|
| | Lead (Pb) | Mercury (Hg) | Cadmium (Cd) | Hexavalent chromium (Cr (VI)) | Polybrominated biphenyl (PBB) | Polybrominated diphenyl ether (PBDE) |
| Compressor and accessories | × | ○ | × | ○ | ○ | ○ |
| Heat exchanger | ○ | ○ | ○ | ○ | ○ | ○ |
| Pipe fittings and valves | × | ○ | ○ | ○ | ○ | ○ |
| Refrigerant | ○ | ○ | ○ | ○ | ○ | ○ |
| Motor | × | ○ | × | ○ | ○ | ○ |
| Control box and electrical components | × | ○ | × | ○ | ○ | ○ |
| Power cords and cables | × | ○ | ○ | ○ | ○ | ○ |
| Fasteners such as screws and gaskets | × | ○ | ○ | ○ | ○ | ○ |
| Rubber parts | ○ | ○ | ○ | ○ | ○ | ○ |
| Other metal parts | ○ | ○ | ○ | ○ | ○ | ○ |
| Other plastic parts | ○ | ○ | ○ | ○ | ○ | ○ |
| Printed parts | ○ | ○ | ○ | ○ | ○ | ○ |
| Foam pieces | ○ | ○ | ○ | ○ | ○ | ○ |
| Insulated cotton | ○ | ○ | ○ | ○ | ○ | ○ |

The sheet is prepared in accordance with the specification of SJ/T 11364.

○: It indicates that the content of this hazardous substance in all homogeneous materials of this part is below the limit specified by GB/T 26572.

×: It indicates that the content of the hazardous substance in at least one of the homogeneous materials of the part exceeds the limit specified by GB/T 26572. However, it is temporarily impossible to realize that the product parts are completely free from the above-mentioned hazardous substances under the existing technical conditions. The above-mentioned harmful substances will be gradually reduced with the progress of alternative technologies.

To protect the environment and human health:

- This product packaging can be recycled. After the product is scrapped, please separate it from domestic garbage. Consumers shall be responsible for returning it to a qualified recycling point.
- The recycling center will recycle the product materials through appropriate methods.
- For details on recycling this product, please consult your local government, waste disposal center or distributor.

Blauberg Ventilatoren GmbH
Aidenbachstr. 52
D-81379 Munich

info@blaubergventilatoren.de
www.blaubergventilatoren.de